



Product Information

SU1-TWIST • CompactPCI® Serial • Quad Port Isolated RS-485 I/F



Short Description

Proven and reliable, RS-485 (EIA/TIA-485) stays a popular fieldbus communication interface, due to simple installation via low cost twisted pair copper cables, up to 1200m length.

The SU1-TWIST is a peripheral slot card for CompactPCI® Serial systems, based on PCI Express®. The board is equipped with four isolated front panel RS-485 ports. High speed RS-485 balanced line transceivers with internal 5kV isolation barrier provide for optimum noise and EMC immunity.

The SU1-TWIST is equipped with an octal PCI Express® to UART bridge. The 950-style UARTs are compatible with many asynchronous serial applications and protocols. Four isolated EIA/TIA-485 transceivers are wired to Micro-D front panel connectors, individually configurable for full-duplex operation (4+1 wire cable) or half-duplex (2+1 wire cable), either point-to-point or multipoint applications. Another four UART channels are available via the CompactPCI® Serial backplane connector P4 for versatile rear I/O usage.



Feature Summary

Feature Summary

CompactPCI® Serial

- ▶ PICMG® CompactPCI® Serial (CPCI-S.0) standard
- ▶ Single size Eurocard 3U 4HP 100x160mm²
- ▶ Suitable for CompactPCI® Serial peripheral slot (PCI Express® enabled)
- ▶ CompactPCI® Serial backplane connector P1 for PCI Express®, single lane link
- ▶ Option CompactPCI® Serial backplane connector P4 for rear I/O

UART

- ▶ Pericom® PCI Express® octal UART PI7C9X7958
- ▶ High performance 950-class UARTs
- ▶ 16C550 software compatible
- ▶ 128-Byte FIFO for each transmitter/receiver
- ▶ Baud rate up to 15Mbps
- ▶ XON/XOFF in-band flow control
- ▶ CTS/RTS or DSR/DTR out-of-band control & driver enable signal for PartyLine operation
- ▶ Data frame 5, 6, 7, 8 and 9 bits
- ▶ Clock prescaling 4 to 46
- ▶ Windows® WHQL device driver support

RS-485 Transceivers

- ▶ 5kV rms isolation barrier RS-485/RS-422 transceivers (Analog Devices ADM2682)
- ▶ Configurable as half- or full-duplex
- ▶ ±15 kV ESD protection on RS-485 input/output pins
- ▶ Transceiver data rate 16Mbps max.
- ▶ Connect up to 256 nodes on one PartyLine bus (driver enable control via dedicated UART mode select outputs)
- ▶ Open- and short-circuit, fail-safe receiver inputs
- ▶ High common-mode transient immunity >25 kV/μs
- ▶ Thermal shutdown protection

Feature Summary

Front Panel I/O

- ▶ 4 x Front panel Micro-D 9-pin high density male connectors
- ▶ RS-485 front ports isolated against each other and board circuitry
- ▶ On-board DIP-switches for full/half-duplex setting, and line termination on/off
- ▶ Micro-D cable assemblies available, e.g. Micro-D to classic style D-Sub male or female
- ▶ Ordering option D-Sub 9-pin front panel connectors (4 ports require 8HP F/P)
- ▶ Option 2 x D-SUB9 front panel connectors on request (4HP, 2 x micro ribbon flat cable assembly)
- ▶ Option 3 x D-SUB9 front panel connectors on request (4HP, front handle replaced by screw lock)
- ▶ Option 4 x D-SUB9 front panel connectors on request (8HP, 4 x micro ribbon flat cable assembly)

Rear I/O (Option)

- ▶ 4 x Rear I/O UART ports (TTL Level), wired to P4 for optional usage with RIO module
- ▶ Each rear I/O UART port suitable for versatile use with an appropriate transceiver on a RIO module, e.g. RS-232 or RS-485, isolated or non-isolated
- ▶ Standard rear I/O modules available (SUA-RIO for 4 x RS-232 isolated, SUB-RIO for 4 x RS-485 isolated)
- ▶ Option all 8 ports available for rear I/O (SUC-RIO)
- ▶ EKF offers also custom specific rear I/O module design

Environment, Regulatory

- ▶ Designed & manufactured in Germany
- ▶ Certified quality management according to ISO 9001
- ▶ Long term availability
- ▶ Rugged solution (coating, sealing, underfilling on request)
- ▶ Custom specific modifications on request
- ▶ RoHS compliant
- ▶ Operation temperature -40°C to +85°C (industrial temperature range)
- ▶ Storage temperature -40°C to +85°C, max. gradient 5°C/min
- ▶ Humidity 5% ... 95% RH non condensing
- ▶ Altitude -300m ... +3000m
- ▶ Shock 15g 0.33ms, 6g 6ms
- ▶ Vibration 1g 5-2000Hz
- ▶ MTBF 43.5 years
- ▶ EC Regulatory EN55035, EN55032, EN62368-1 (CE)

items are subject to changes w/o further notice

Eight Port 4HP Assemblies Front & Rear I/O

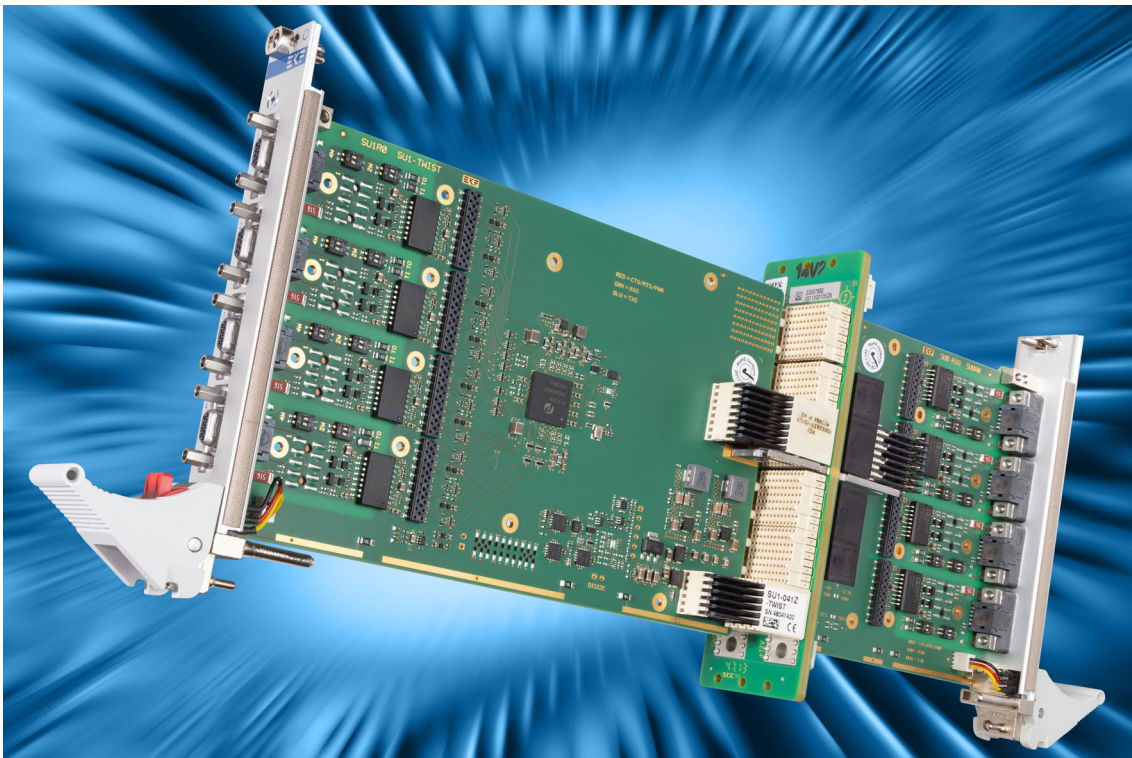

SU1-TWIST w. SUB-RIO (8 Port 4HP Assembly Isolated RS-485)

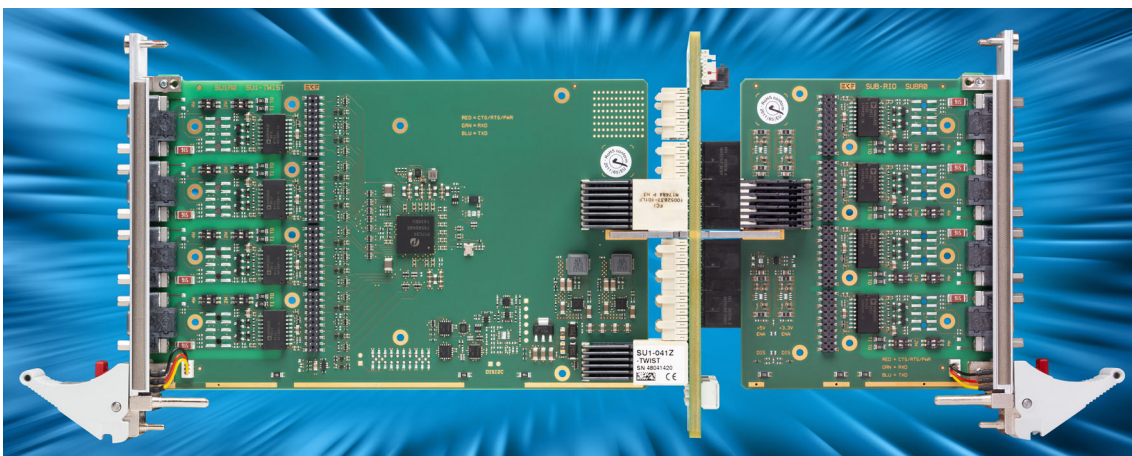

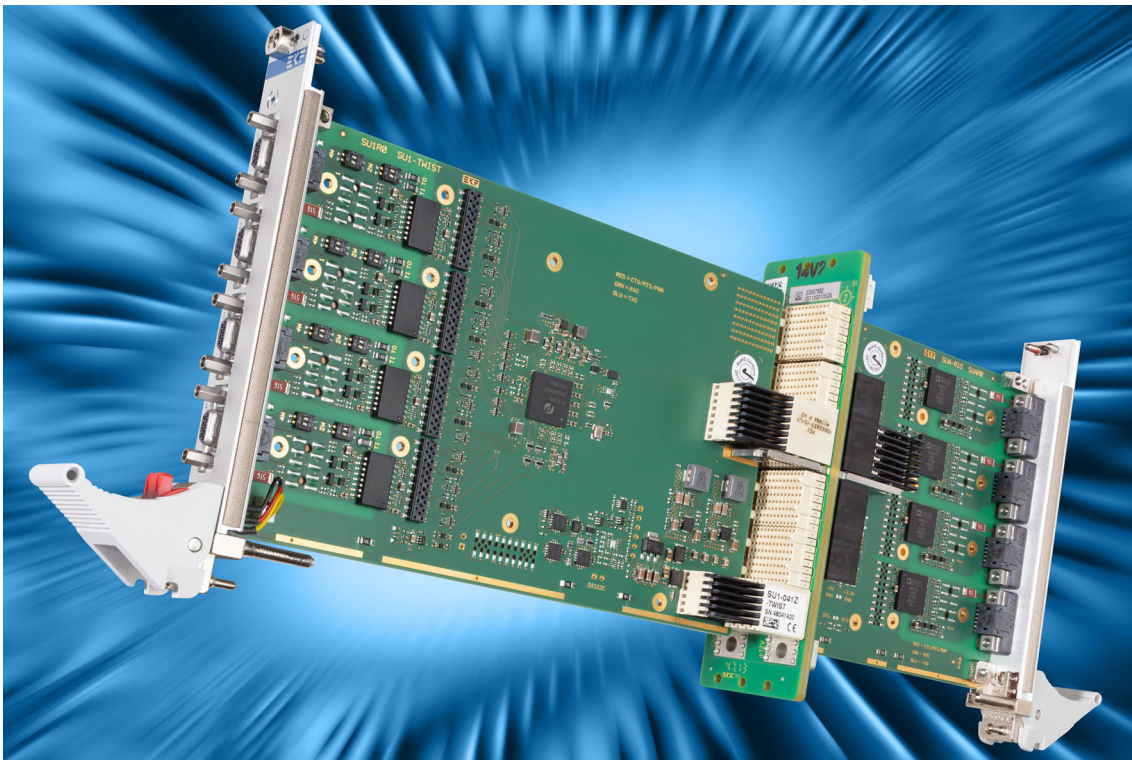

SU1-TWIST w. SUA-RIO (4+4 Port 4HP Assembly Isolated RS-485 & RS-232)

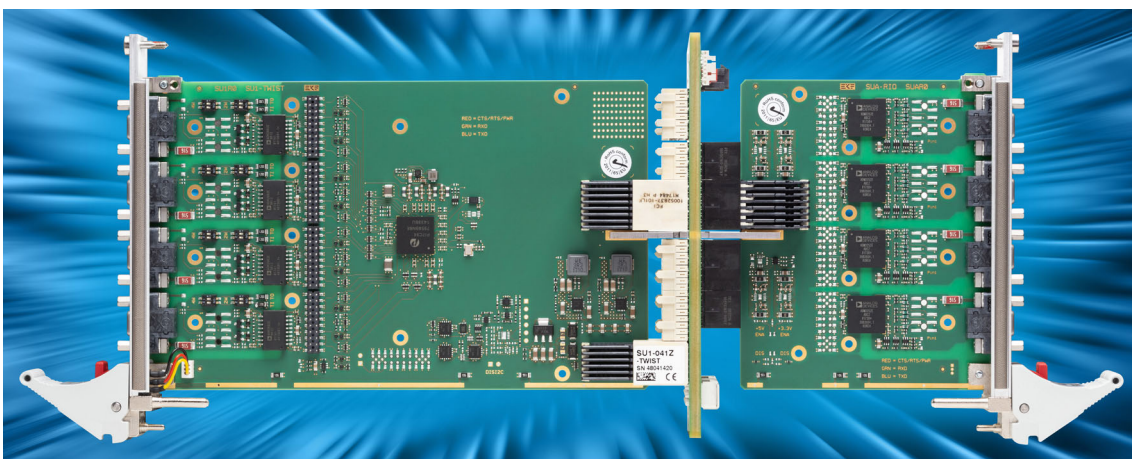

Block Diagram

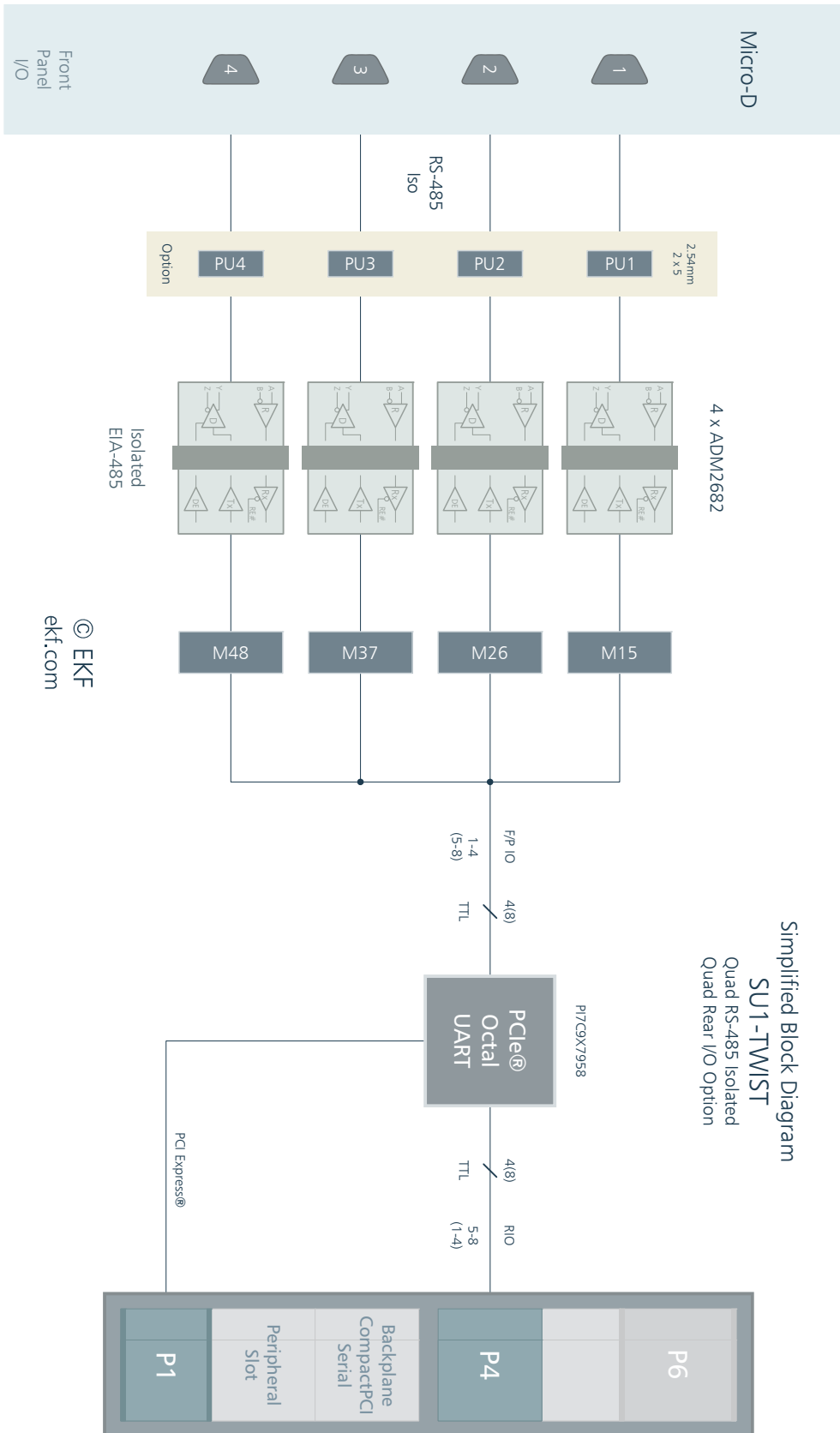

Simplified Block Diagram
 SU1-TWIST
 Quad RS-485 Isolated
 Quad Rear I/O Option

© EKF
 ekf.com

www.ekf.com/s/su1/img/su1_blk.pdf

Theory of Operation

The SU1-TWIST is equipped with the Pericom PI7C9X7958 PCI Express® octal UART, which is suitable for asynchronous baud rates up to 15Mbps. Four UART channels are wired to Micro-D front panel connectors across RS-485 transceivers. According to the RS-485 transmission line standard, only the UART receive and transmit data signals are in use, and in addition output pins which act as RS-485 driver and receiver enable control, as required for half-duplex multipoint configurations (aka party-line).

Four ADM2682E transceivers are provided to meet the RS-485 physical layer specifications. The RS-485 signals of any particular Micro-D high density male front panel connector are isolated from the board circuitry, and also from each other front port. Driver and receiver enable is controlled by dedicated UART signals.

Micro-D to Micro-D cable assemblies are available, as well as Micro-D to D-Sub, and pigtail Micro-D cables in addition.

As an alternate to the Micro-D connectors, four 2.54mm pitch 2x5 position pin headers PU1-4 can be optionally populated on-board, for attachment of classic D-Sub 9-pin connectors by means of micro ribbon flat cables, to be combined with a non-standard 4HP or 8HP width front panel. Three different DB9 pin assignments are available as manufacturing option.

The SU1-TWIST can be configured also for rear I/O usage. Four UART ports are wired as TTL level signals to the optional backplane connector P4, for use with a suitable RIO PHY module, typically configured as either RS-232 or RS-485. Hence, with both front and rear I/O capabilities utilised, the SU1-TWIST is a true 8-port asynchronous serial interface solution.

As an alternate to P4 RIO, optional mezzanine expansion connectors M15 - M48 can be provided on-board, for attachment of individual PHY modules (SU*-Series) and also SUA/SUB-RIO configured as mezzanine card for front panel I/O.

Component Orientation

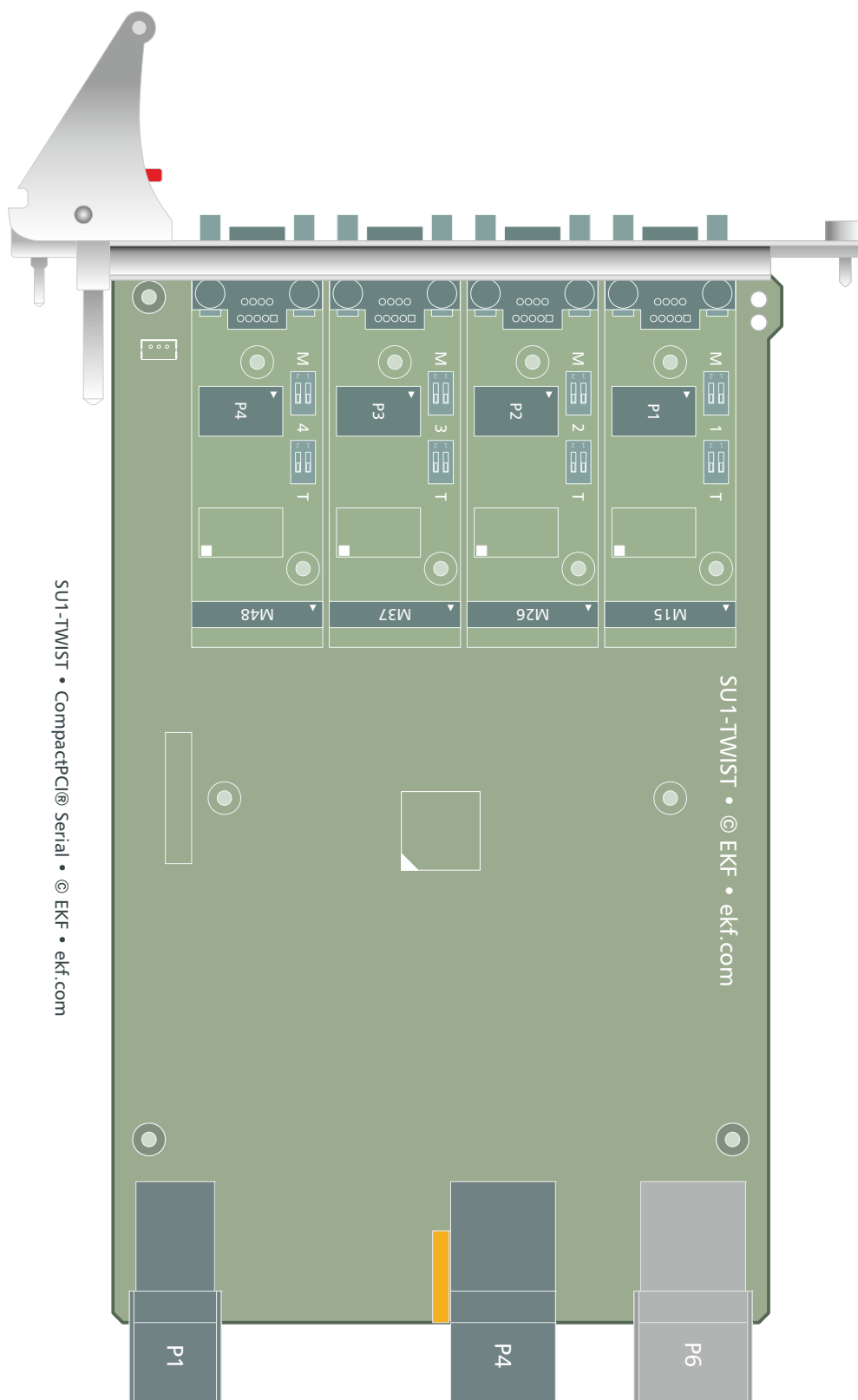

Front Panel

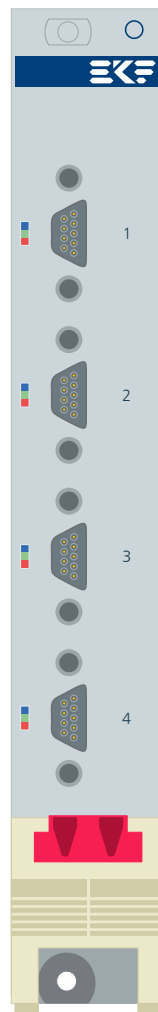

SU1-TWIST

www.ekf.com/s/su1/img/su1_fpl.pdf

triple color LEDs assigned to each connector/port
dark red = isolated power ok
green = receiving data
blue = sending data

Optional 8HP F/P

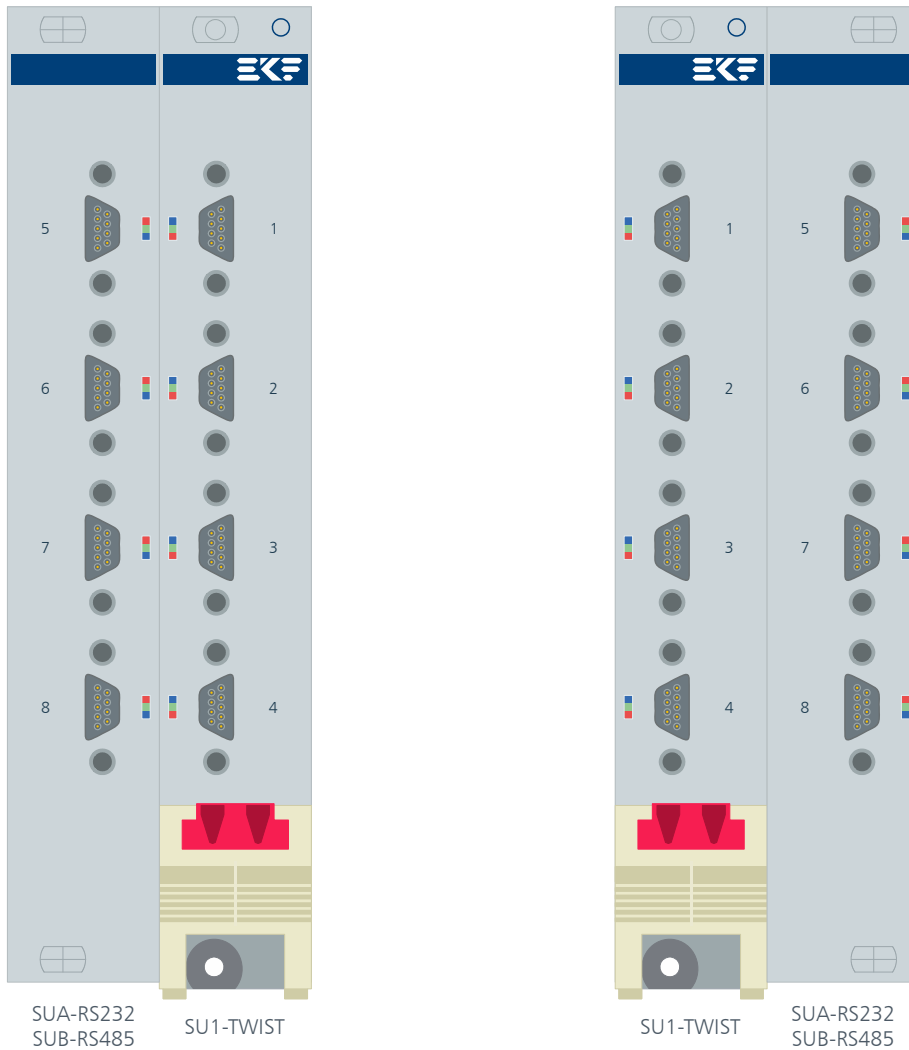

www.ekf.com/s/su1/img/su1_sua_sub_fpl.pdf

As an option, the SU1-TWIST can be ordered with an 8HP front panel for 8 ports. In addition to the SU1-TWIST, a suitable mezzanine card is required, either SUA (4 isolated RS-232 ports) or SUB (4 isolated RS-485 ports). The mezzanine module may be mounted on top of the SU1-TWIST (face-to-face) or on bottom (back-to-back), resulting in different front panel styles.

Option D-SUB F/P

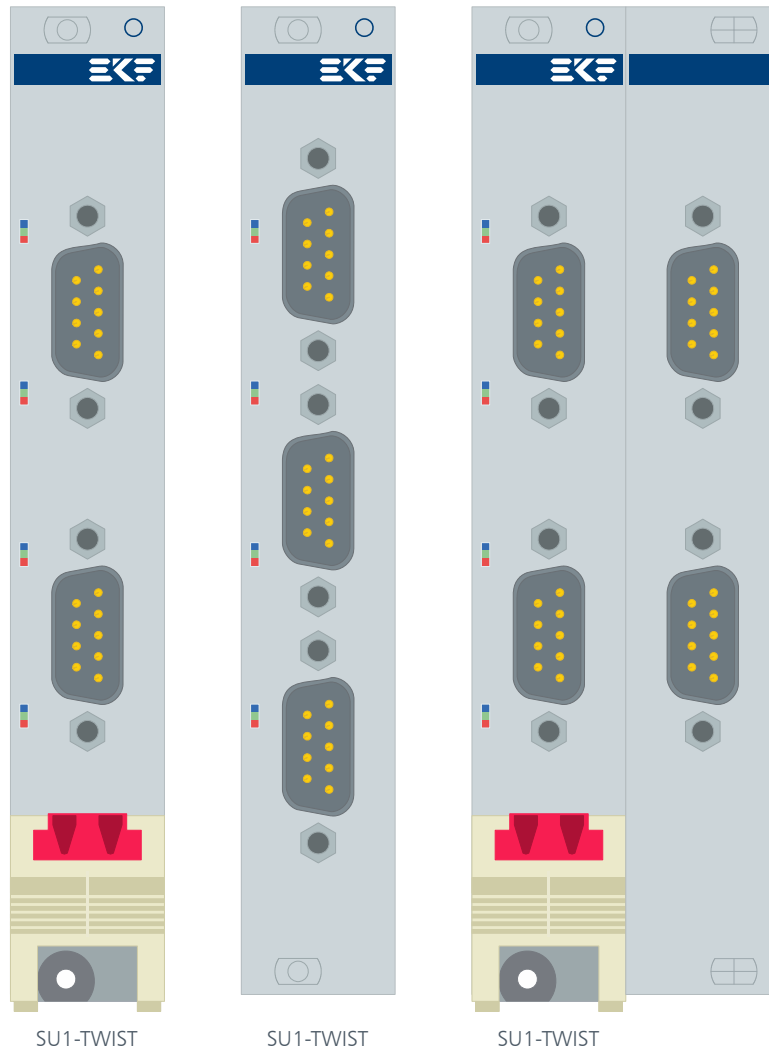

As an option, the SU1-TWIST can be ordered with classic style D-SUB 9-pin male panel mount connectors. Due to space limitations, a 4HP three port configuration comes w/o a front handle (knurled-head screws instead), and a four port solution is available as 8HP assembly only.



Triple D-Sub 4HP F/P Option (Knurled-Head Screws)

Front Panel Connectors

Due to space restrictions, the SU1-TWIST is provided with four Micro-D male connectors, which are considerably smaller than standard D-Sub connectors and therefore allow a 4HP panel for the board. The Micro-D connector pin assignment is illustrated below (view on rear panel).

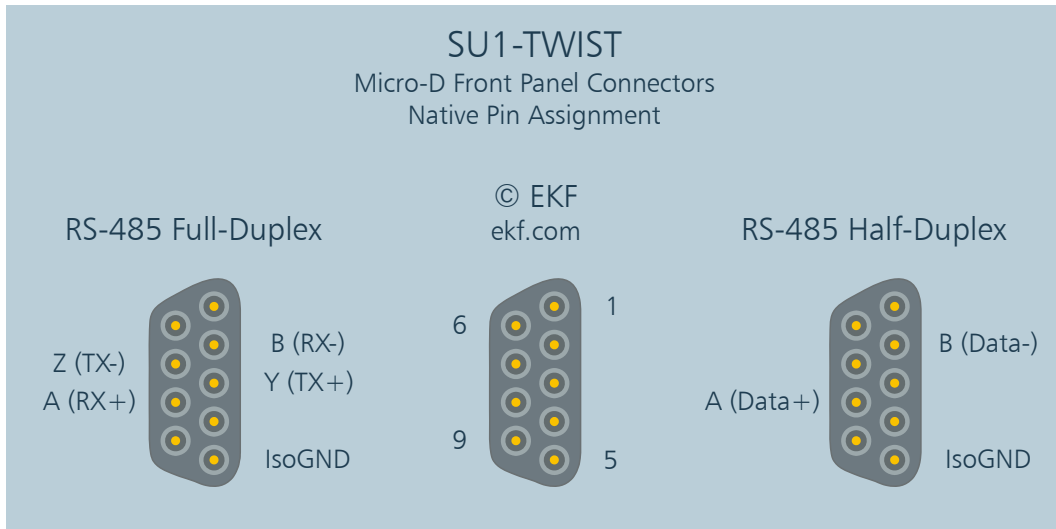

IsoGND is the reference ground for the RS-485 signals (see also chapter 'Is RS-485 a Two-Wire Connection?'). IsoGND is isolated from the board and system logic GND, and from Shield (panel/chassis).

A minimum cabling solution requires 2+1 wires (PartyLine Half-Duplex mode), or 4+1 (Full-Duplex).

Micro-D Cables

Some ready to use adapter cable assemblies are available from stock, e.g. Micro-D to D-Sub (female or male), wired straight pin to pin. In addition, custom specific cable assemblies are available on request.

| EKF Part Numbers Micro-D Cable Assemblies RS-232 | |
|--|---|
| 259.901.0009.18 | Micro-D to Micro-D cable assembly, 9 circuits, 1.8m, female to female cable connectors |
| 259.921.0009.18 | Micro-D to D-SUB cable assembly, 9 circuits, 1.8m, Micro-D female connector to male D-SUB |
| 259.931.0009.18 | Micro-D to D-SUB cable assembly, 9 circuits, 1.8m, Micro-D female connector to female D-SUB |
| 259.951.0009.18 | Micro-D single ended cable assembly, 9 circuits, 1.8m, Micro-D female connector to pigtail |



Micro-D to Micro-D Cable Assembly (Picture Similar)

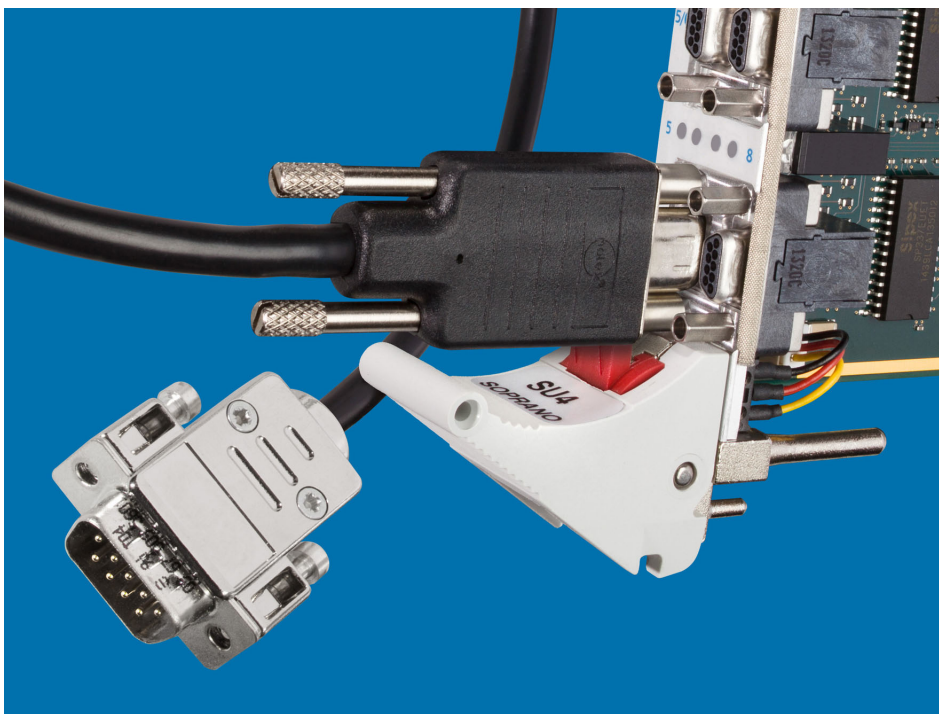

Micro-D to D-SUB Cable Assembly (Picture Similar)

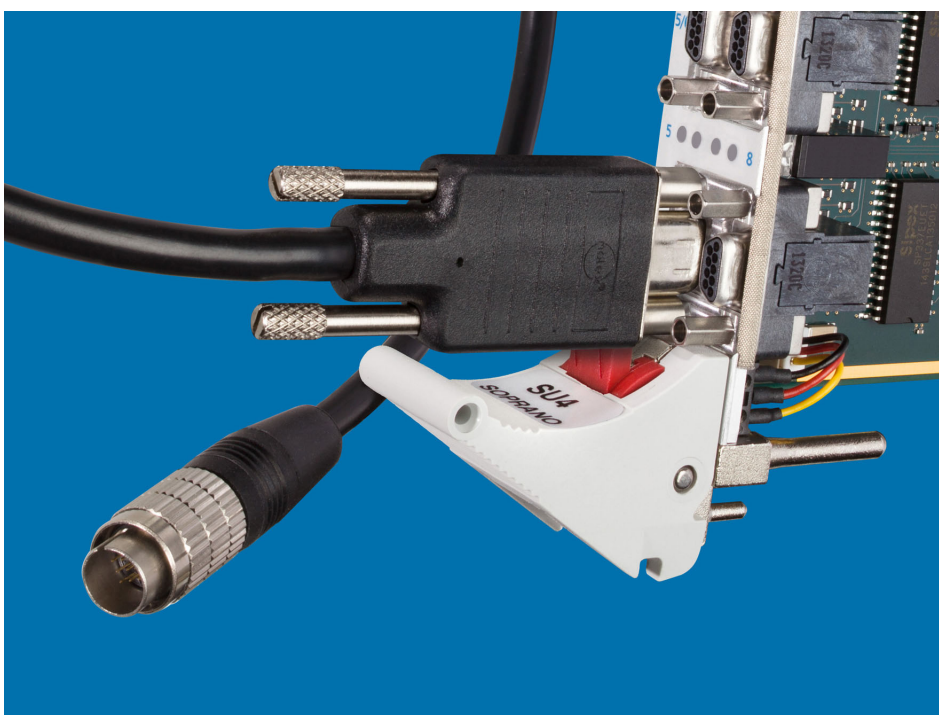

Micro-D to Custom Specific Connector Cable Assembly (Picture Similar)

Transceiver Schematics

Illustrated below is the default transceiver circuitry. The light blue zone is the isolated area (front panel connectors). Please refer to the DIP-Switch configurations (chapter 'RS-485 Half-Duplex vs. Full-Duplex') for operation mode and line termination settings.

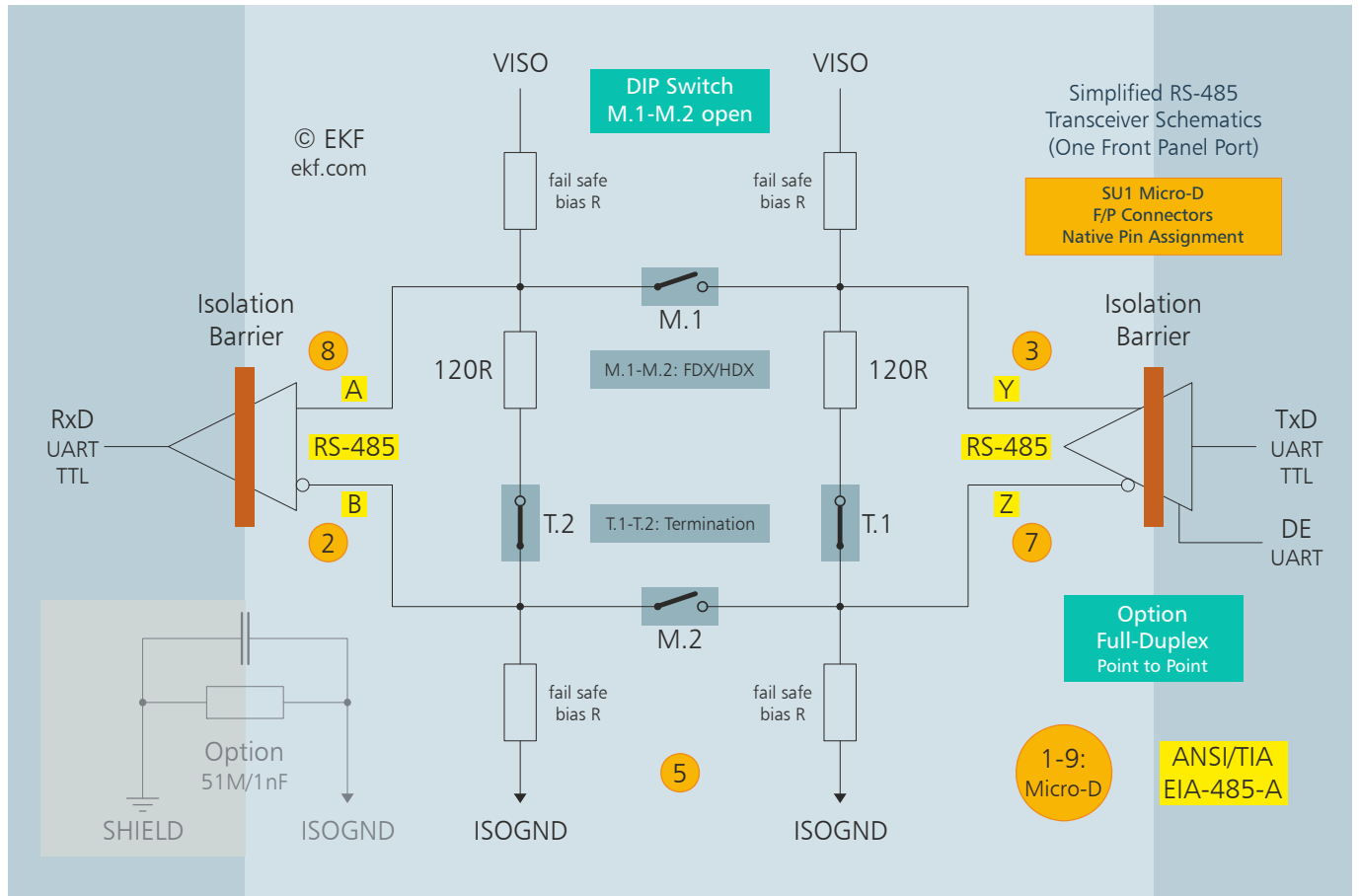

Illustrated above is a point-to-point 4-wire configuration (in addition to reference ground wire). Switches M.1 and M.2 are open. Setting of line termination switches T.1 and T.2 depends on data transfer bit rate and cable length. Normally set both switches on (off if external termination is applied).

Pin Headers for Option Front Panel D-Sub Connectors

The SU1-TWIST can be equipped with pin headers for attachment of classic male 9-pin D-Sub front panel connectors, as an alternate to the Micro-D connectors. This ordering option however requires an 8HP front panel for the quad port RS-485 solution, and micro ribbon flat cable assemblies. There are three different pin configurations available (board manufacturing options). Shown below is the recommended pin assignment which results in a DB9 wiring diagram as used on the closely related DU1-MUSTANG XMC module.

| P1 - P4 Option Dual-Row Header 2.54mm EKF Part No. 241.1.0205.20.00 | | | |
|---|---|----|--------|
| Shield | 1 | 2 | IsoGND |
| B | 3 | 4 | A |
| IsoGND | 5 | 6 | IsoGND |
| Z | 7 | 8 | Y |
| IsoGND | 9 | 10 | |

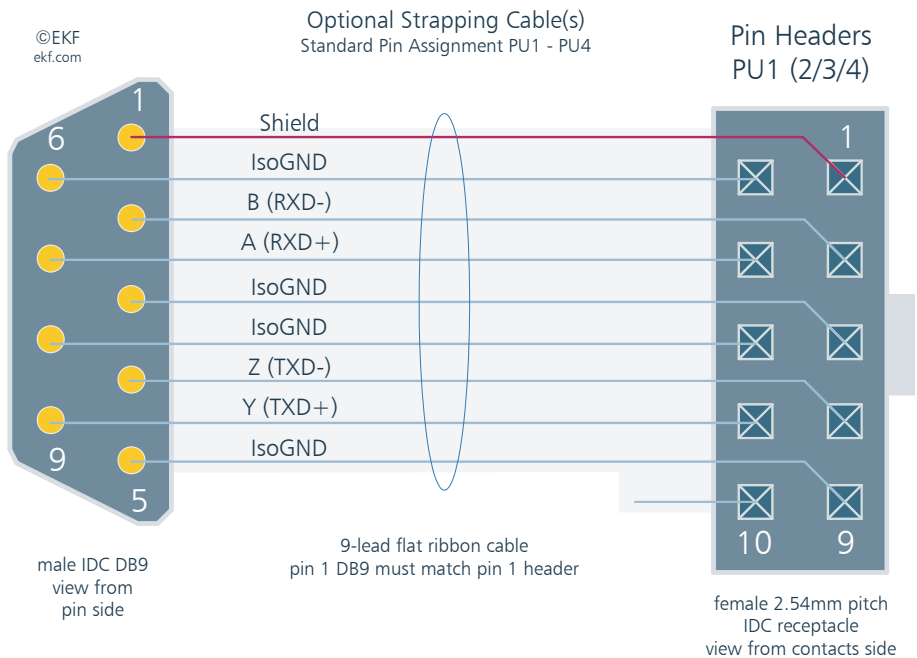

Assuming IDC connectors at both endings of a micro ribbon flat cable, the resulting pin assignment on a 9-position male D-Sub connector is shown in the table below:

| SU1-TWIST D-Sub Front Panel Option (DU1-MUSTANG) | | |
|--|---|--------------------------|
| Serial Ports 1 - 4 • Option Male D-Sub 9 | | |
| 1.27mm Pitch Flat Cable IDC Connectors | | |
| | 1 | Shield (Frame Ground) |
| | 2 | B (Inverting Input) |
| | 3 | Isolated Ground |
| | 4 | Z (Inverting Output) |
| | 5 | Isolated Ground |
| | 6 | Isolated Ground |
| | 7 | A (Non-Inverting Input) |
| | 8 | Isolated Ground |
| | 9 | Y (Non-Inverting Output) |

The default D-Sub pin assignment shown above is identical to the Micro-D connectors. Hence, a cable assembly 1:1 Micro-D to D-Sub could be considered as alternate.



SU1-TWIST w. Triple Standard D-Sub 4HP

Another board manufacturing legacy option is the signal assignment used on the CU4-SOPRANO P1 - P4 pin headers:

| P1 - P4 (CU4-SOPRANO Legacy P1-P4 Pin Assignment) Option Dual-Row Header 2.54mm EKF Part No. 241.1.0205.20.00 | | | |
|--|---|----|----------|
| | 1 | 2 | |
| B (RXD-) | 3 | 4 | Z (TXD-) |
| Y (TXD+) | 5 | 6 | A (RXD+) |
| | 7 | 8 | |
| IsoGND | 9 | 10 | |

Assuming IDC connectors at both endings of a micro ribbon flat cable, the resulting pin assignment on a 9-position male D-Sub connector is shown in the table below:

| SU1-TWIST D-Sub Front Panel Option (CU4-SOPRANO Legacy) Serial Ports 1 - 4 • Option Male D-Sub 9 1.27mm Pitch Flat Cable IDC Connectors | | |
|---|---|--------------------------|
| | 1 | |
| | 2 | B (Inverting Input) |
| | 3 | Y (Non-Inverting Output) |
| | 4 | |
| | 5 | Isolated Ground |
| | 6 | |
| | 7 | Z (Inverting Output) |
| | 8 | A (Non-Inverting Input) |
| | 9 | |

A third board manufacturing option is the signal assignment used for a custom specific layout, referenced here as 'WL':

| P1 - P4 (WL Pin Assignment) Option Dual-Row Header 2.54mm EKF Part No. 241.1.0205.20.00 | | | |
|---|---|----|--|
| A (RXD+/TXD+) | 1 | 2 | |
| | 3 | 4 | |
| B (RXD-/TXD-) | 5 | 6 | |
| | 7 | 8 | |
| IsoGND | 9 | 10 | |

Assuming IDC connectors at both endings of a micro ribbon flat cable, the resulting pin assignment on a 9-position male D-Sub connector is shown in the table below:

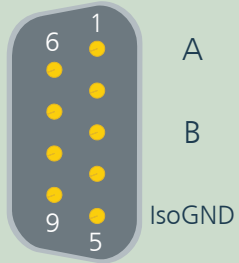
| SU1-TWIST D-Sub Front Panel Option (WL) Serial Ports 1 - 4 • Option Male D-Sub 9 1.27mm Pitch Flat Cable IDC Connectors | | |
|---|---|-----------------------|
|  <p>CUD TWIST • WL</p> | 1 | A (Non-Inverting I/O) |
| | 4 | |
| | 3 | B (Inverting I/O) |
| | 4 | |
| | 5 | Isolated Ground |
| | 6 | |
| | 4 | |
| | 4 | |
| | 9 | |

RS-485 Half-Duplex vs. Full-Duplex

For a full-duplex RS-485 point-to-point application, the receiver data lines A/B and the driver signals Y/Z require a twisted-pair wire each, plus reference ground, resulting in a total of 2x2+1 wires. By specification, RS-485 requires a common ground - this is referred to as signal C in the ANSI EIA-485 document. In many cases the additional ground wire can be omitted, if all RS-485 nodes are properly grounded. Sometimes the RS-485 cable shield is used as common ground.

For a half duplex RS-485 point-to-point or multipoint application, the receiver data lines A/B and the driver signals Y/Z must be tied together (A=Y, B=Z). This solution requires a single twisted-pair wire, resulting in a 2+1 wire cable. The strapping between A/Y and B/Z will be often done externally, e.g. within the shell of a cable connector. As an alternate, the SU1-TWIST provides on-board DIP-switches, which allow to join A/Y and B/Z internally (M.1=ON M.2=ON).

| Termination DIP Switch (Each Port) | | |
|---|------|--------------------------------------|
| EKF Part No. 160.15.02.0 | | |
|  | 1=ON | Y/Z (Output) Termination 120R Active |
| | 2=ON | A/B (Input) Termination 120R Active |

| Mode DIP Switch Half-/Full-Duplex Configuration (Each Port) | | |
|---|-------------|-------------------------------------|
| EKF Part No. 160.15.02.0 | | |
|  | 1=OFF 2=OFF | Full-Duplex RS-485 (Point-to-Point) |
| | 1=ON 2=ON | Half-Duplex RS-485 (PartyLine) |

Full-Duplex 4+1 Wire (Internal Termination)

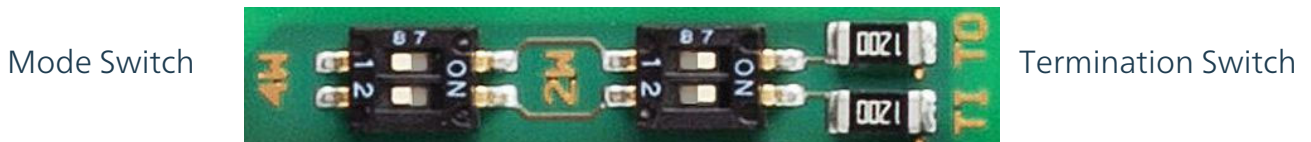

Half-Duplex 2+1 Wire (Internal Termination)

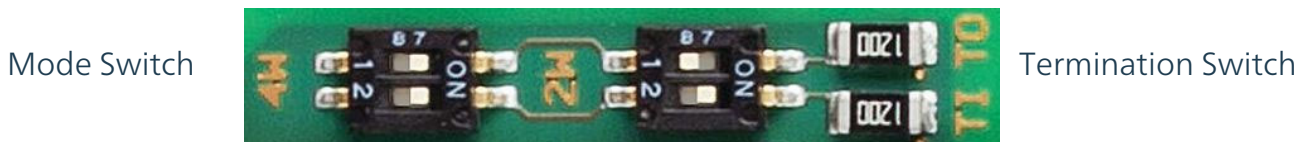

RS-485 Line Termination

For signal integrity, both extreme ends of a RS-485 bus must be terminated, typically 120 Ohm between A/B and also Y/Z (full-duplex only), ideally matching the twisted pair cable impedance. A popular approach is to use external termination, having the resistors located within the shell of the Micro-D or D-SUB cable connectors. As an alternate, the SU1-TWIST provides on-board DIP-switches, which can individually activate internal termination resistors on A/B and Y/Z.

By default, the internal termination is achieved by 120 Ohm (DC termination), for maximum signal integrity with long cables and high data transfer rates. If no termination is required, set the port termination switches to off. In addition, each RS-485 port is provided with fail-safe bias resistors, 549R to ISOGND at the inverting inputs/outputs (B/Z), and 549R to VISO at the non-inverting inputs/outputs (A/Y). Each line is overvoltage protected by TVS components (PSD12C combined with SM712).

Isolation Voltage

The ADM2682E on-board transceivers withstand 5kVrms, which is far more than can be achieved for the SU1-TWIST assembly. The maximum safe isolation voltage depends mainly on the voltage rating specified for the Micro-D or D-SUB connectors in use (signal pins to frame/chassis ground).

For personal safety, EKF recommends strongly to limit a superimposed external voltage to less than 60V, measured against protective earth.

In most cases, the reason for a superimposed voltage would be a ground loop, electromagnetic interference and/or electrostatic charging due to a long RS-485 cable. Whenever suitable, tie together externally (e.g. within the mating cable connector) isolated ground and shield, or couple loosely by 51M Ω /1nF 500VAC in parallel. On request, the SU1-TWIST can be manufactured with these components populated on-board, for each port individually.

Is RS-485 a Two-Wire Connection?

Is RS-485 a two-wire or a three-wire system? It is most definitely a three wire system (four plus one wire with respect to full-duplex operation). The TIA standard (ANSI/TIA/EIA-485-A, page 15, A.4.1) requires the presence of a common return path between all circuit grounds along the balanced line for proper operation.

The TIA standard defines a maximum common mode voltage range from -7V to +12V on the signal lines A and B, measured against C (common ground). A TIA/EIA-485 system however with only two wires A and B (C generator and C' receiver commons not connected) can result in an unpredictable common mode voltage superimposed on the interface lines A and B, caused either by electrostatic charging or electromagnetic interference.

A 2-wire system often may work though due to idle-line fail-safe resistors at the receiver inputs, which can be considered as a loosely coupled common ground. Nevertheless this operation mode cannot be recommended - what is working flawless in the laboratory may not work reliable under real conditions in an industrial environment.

Where do we get the third wire? Many times inner and/or outer cable shields are used as the third (fifth) wire. When using a twisted pair Ethernet cable as RS-485 transmission line, two or more wires are available for common ground.

ANSI/TIA/EIA-485-A Interconnect Application



G = Generator • R = Receiver • RT = Termination Resistor
 A/A' = Generator/Receiver Interface Point
 B/B' = Generator/Receiver Interface Point
 C/C' = Generator/Receiver Common

www.ekf.com/s/su1/img/rs485_common_ground.pdf

Useful External Documents

| | |
|---------------------|--|
| Wikipedia | RS-485 Three-wire connection https://en.wikipedia.org/wiki/RS-485#Three-wire_connection |
| Article/ Blog | RS485 Cables – Why you need 3 wires for 2 (two) wire RS485 • www.chipkin.com/articles/rs485-cables-why-you-need-3-wires-for-2-two-wire-rs485/ |
| Application Note | AN960 • RS-485/RS-422 Circuit Implementation Guide • www.analog.com/static/imported-files/application_notes/AN-960.pdf |

Standards - Specifications

| Term | Document | Origin |
|--------------------|---|--|
| CompactPCI® Serial | CompactPCI® Serial Specification, PICMG® CPCI-S.0 R2.0 | www.picmg.org |
| PCI Express® | PCI Express® Base Specification | www.pcisig.com |
| RS-485 | ANSI/TIA/EIA-485-A Standard Electrical Characteristics of Generators and Receivers for Use in Balanced Digital Multipoint Systems | www.tiaonline.org |

Sockets M15 - M48

As an option, the SU1-TWIST can be equipped with four pass-through sockets, each wired to 2 UART channels, suitable for attachment of EKF SU-series PHY modules and the SUA-RS232 or SUB-RS485 quad transceiver mezzanine cards. Normally the UART ports 1 - 4 are in use on the SU1-TWIST itself for the on-board RS-2485 transceivers, so only the UART ports 5 - 8 are typically available for expansion modules.

A mezzanine expansion module connects to the the SU1-TWIST carrier card via pin stackers, and can be mounted either on top (face-to-face) or to the bottom (back-to-back). Both alternates result in an 8HP front panel.

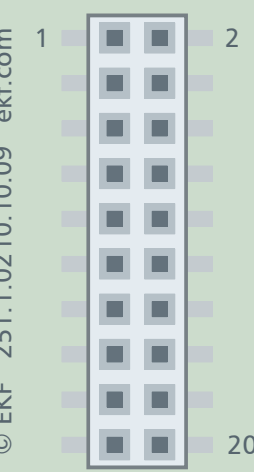
| M15 - M48 • TTL-Level Serial I/O | | | | | |
|--|------------|--|----|----|------------|
| 2.00mm Socket Strip 2 x 10 (251.1.0210.10.09) | | | | | |
|  | +5V | | 1 | 2 | GND |
| | RTS# (1-4) | | 3 | 4 | RXD (1-4) |
| | TXD (1-4) | | 5 | 6 | +3.3V |
| | DE (1-4) | | 7 | 8 | CTS# (1-4) |
| | RE# (1-4) | | 9 | 10 | GND |
| | RE# (5-8) | | 11 | 12 | GND |
| | DE (5-8) | | 13 | 14 | CTS# (5-8) |
| | TXD# (5-8) | | 15 | 16 | +3.3V |
| | RTS# (5-8) | | 17 | 18 | RXD (5-8) |
| | +5V | | 19 | 20 | GND |

Driver enable (DE) and receiver enable (RE#) are required for RS-485 mezzanines configured for half-duplex (PartyLine) operation. The driver enable signal is generated by the on-board Pericom UART in conjunction with the Pericom driver software.

Please note: The serial ports 5 - 8 provided by the UART are also available for rear I/O across P4 (stuffing option). In order to avoid signal interference and malfunction, attach a transceiver module or other circuitry to these ports only once, either to the pin headers M15 - M48, or through a rear I/O transition module via P4.

CompactPCI® Serial Backplane Connectors

CompactPCI® Serial Peripheral Slot Connector P1

The SU1-TWIST is equipped with a PCI Express® based UART (Gen1 single lane). The card can be inserted in any PCIe enabled peripheral slot of the CompactPCI® Serial backplane for proper operation.

| P1 CompactPCI® Serial Peripheral Slot Backplane Connector | | | | | | | | | | | | |
|---|-------------|-------------|-------------|-------------|-------------|-------------|-------------|-------------|-------------|-------------|-------------|-------------|
| EKF Part #250.3.1206.20.02 • 72 pos. 12x6, 14mm Width | | | | | | | | | | | | |
| P1 | A | B | C | D | E | F | G | H | I | J | K | L |
| 6 | GND | PE TX02+ | PE TX02- | GND | PE RX02+ | PE RX02- | GND | PE TX03+ | PE TX03- | GND | PE RX03+ | PE RX03- |
| 5 | PE TX00+ | PE TX00- | GND | PE RX00+ | PE RX00- | GND | PE TX01+ | PE TX01- | GND | PE RX01+ | PE RX01- | GND |
| 4 | GND | USB2+ | USB2- | GND | PE CLK+ | PE CLK- | GND | SATA TX+ | SATA TX- | GND | SATA RX+ | SATA RX- |
| 3 | USB3 TX+ | USB3 TX- | GA0 | USB3 RX+ | USB3 RX- | GA1 | SATA SDI | SATA SDO | GA2 | SATA SCL | SATA SL | GA3 |
| 2 | GND | I2C SCL | I2C SDA | GND | RSV | RSV | GND | RST# | WAKE# | GND | PE EN# | SYS EN# |
| 1 | +12V | STBY | GND | +12V | +12V | GND | +12V | +12V | GND | +12V | +12V | GND |

pin positions printed white/grey: not connected

Rear I/O Connector P4 (Option)

Four or even all eight SU1-TWIST UART ports (TTL level signals) can be used for rear I/O usage. In addition, a suitable rear I/O module would be required for rear I/O operation, which provides the physical transceivers and rear panel I/O connectors.

Population of P4 may be optional - please consider your requirements before ordering.

| P4 CompactPCI® Serial Peripheral Slot Backplane Connector Type B | | | | | | | | | | | | |
|--|-----|-------------|-------|-------------------|------------------|-------------------|-----------------|------------------|-----------------|-------------------|------------------|-------------------|
| EKF Part #250.3.1208.20.00 • 96 pos. 12x8, 16mm Width | | | | | | | | | | | | |
| P4 | A | B | C | D | E | F | G | H | I | J | K | L |
| 8 | GND | +3.3V | +3.3V | GND | UART 1 RXD | UART 1 RTS# | GND | UART 1 RE# | UART 1 DE | GND | UART 1 TXD | UART 1 CTS# |
| 7 | +5V | I2C CLK | GND | UART 5 CTS# | UART 5 TXD | GND | UART 5 DE | UART 5 RE# | GND | UART 5 RTS# | UART 5 RXD | GND |
| 6 | GND | +3.3V | +3.3V | GND | UART 2 RXD | UART 2 RTS# | GND | UART 2 RE# | UART 2 DE | GND | UART 2 TXD | UART 2 CTS# |
| 5 | +5V | I2C DAT | GND | UART 6 CTS# | UART 6 TXD | GND | UART 6 DE | UART 6 RE# | GND | UART 6 RTS# | UART 6 RXD | GND |
| 4 | GND | +3.3V | +3.3V | GND | UART 3 RXD | UART 3 RTS# | GND | UART 3 RE# | UART 3 DE | GND | UART 3 TXD | UART 3 CTS# |
| 3 | +5V | I2C PWR | GND | UART 7 CTS# | UART 7 TXD | GND | UART 7 DE | UART 7 RE# | GND | UART 7 RTS# | UART 7 RXD | GND |
| 2 | GND | +3.3V | +3.3V | GND | UART 4 RXD | UART 4 RTS# | GND | UART 4 RE# | UART 4 DE | GND | UART 4 TXD | UART 4 CTS# |
| 1 | +5V | RIO ACT# | GND | UART 8 CTS# | UART 8 TXD | GND | UART 8 DE | UART 8 RE# | GND | UART 8 RTS# | UART 8 RXD | GND |

all signals TTL level compliant, +3.45V maximum input voltage
 UART ports 1 - 4 normally in use for front I/O



SUA-RIO (Isolated RS-232)

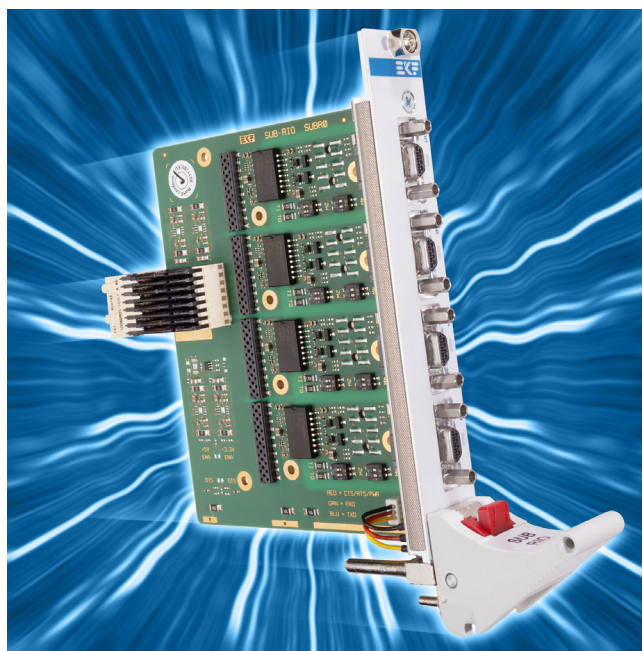

SUB-RIO (Isolated RS-485)

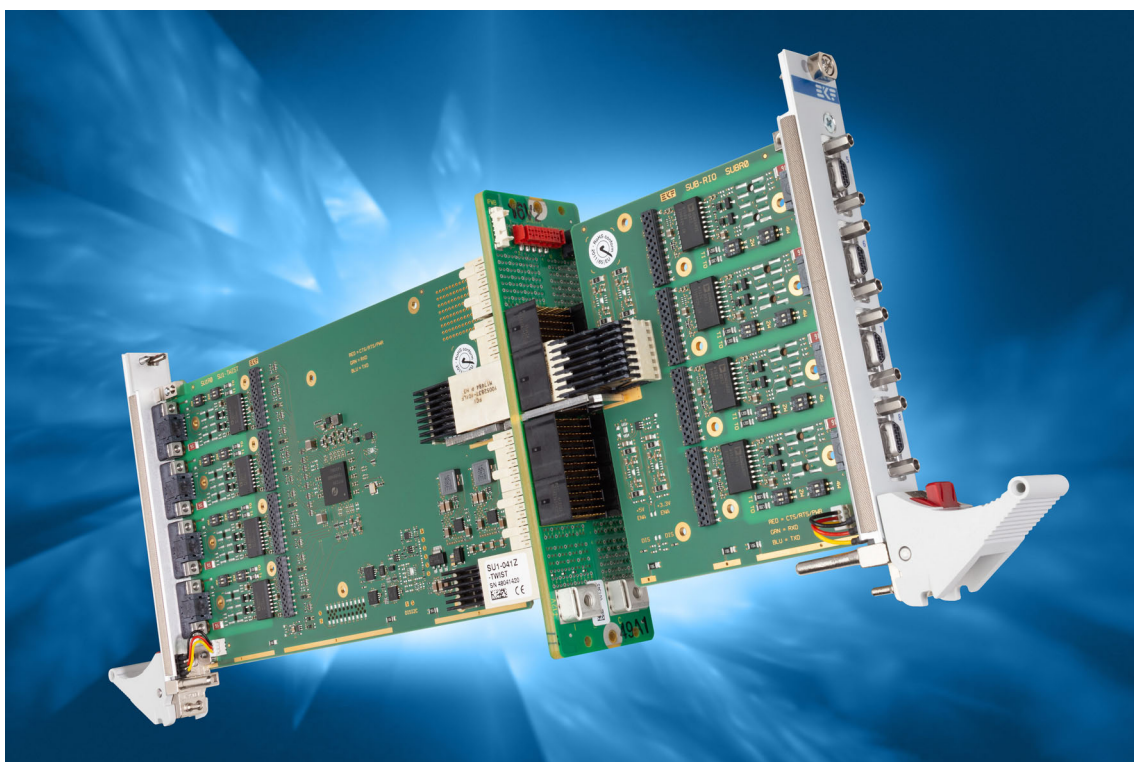



SUC-RIO 4HP (Individually Configurable Ports)



SUC-RIO 8HP (Individually Configurable RS-232/485 Ports)

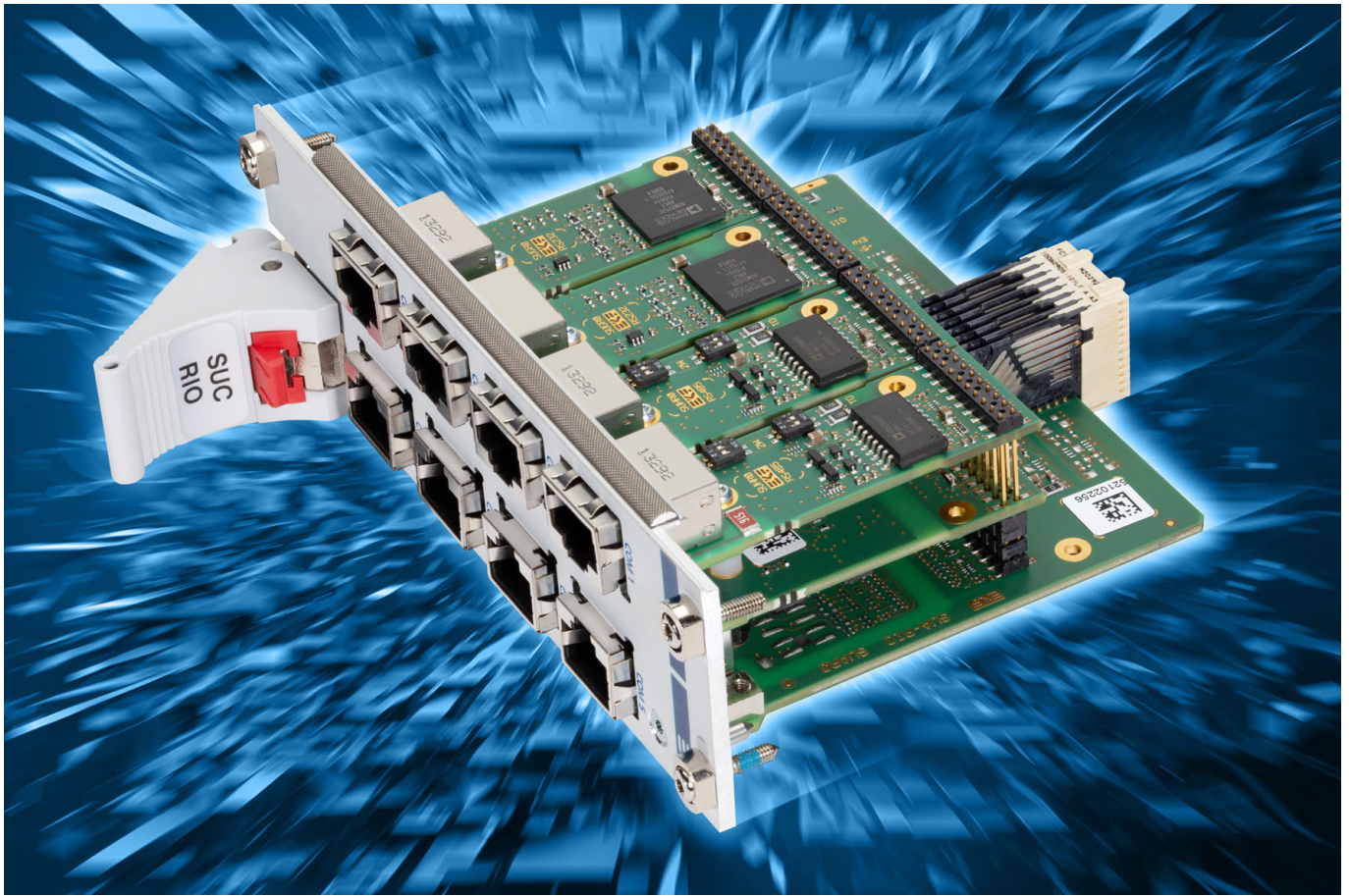

SUC-RIO 8HP (8 Ports Individually Mixed RS-232 RS-485)

Driver Software

UART drivers are available for download from the EKF website e.g. at <https://www.ekf.com/s/su1/drv/>.

Related Products



Related Links

| | |
|--|---|
| SU1-TWIST (Isolated RS-485) | https://www.ekf.com/s/su1/su1.html |
| SU2-BALLAD (Isolated RS-232) | https://www.ekf.com/s/su2/su2.html |
| SU3-ENSEMBLE (Modular Isolated RS-232 RS-485) | https://www.ekf.com/s/su3/su3.html |
| SU4-SOPRANO (RS-232/232 Selectable) | https://www.ekf.com/s/su4/su4.html |
| SUA-RIO (Rear I/O Isolated RS-232) | https://www.ekf.com/s/sua/sua.html |
| SUB-RIO (Rear I/O Isolated RS-485) | https://www.ekf.com/s/sub/sub.html |
| SUC-RIO (Rear I/O Modular Isolated RS-232 RS-485) 4-Port 8-Port (4HP/8HP) | https://www.ekf.com/s/su3/su3.html |
| SUE-SUJ Isolated Transceiver Modules RS-232 & RS-485 | https://www.ekf.com/s/sue-suj/sue-suj.html |
| CompactPCI® Serial UART Solutions | https://www.ekf.com/s/serial.html#SU |
| CompactPCI® Classic UART Solutions | https://www.ekf.com/c/ccom/ccom.html |
| XMC Module UART Solutions | https://www.ekf.com/d/dcom.html |

| Related Products | | |
|------------------|---|--|
| Board | I/F | Use Case |
| SU1-TWIST | 4 x isolated RS-485 Micro-D front 8 x isolated RS-485 Micro-D front 8 x isolated RS-485 Micro-D front & rear 4+4 6 x isolated RS-485 D-Sub front 8 x isolated RS-485 D-Sub front | 4HP F/P, basic version 8HP F/P, w. SUB-RIO as mezzanine module 4HP F/P R/P, w. rear I/O module SUB-RIO 8HP F/P, w. IDC cable assemblies 12HP F/P, w. IDC cable assemblies |
| SU2-BALLAD | 4 x isolated RS-232 Micro-D front 8 x isolated RS-232 Micro-D front 8 x isolated RS-232 Micro-D front & rear 4+4 2 x isolated RS-232 D-Sub front 3 x isolated RS-232 D-Sub front 4 x isolated RS-232 D-Sub front | 4HP F/P, basic version 8HP F/P, w. SUA-RIO as mezzanine module 4HP F/P R/P, w. rear I/O module SUA-RIO 4HP F/P, w. IDC cable assemblies 4HP F/P, w. IDC cable assemblies 8HP F/P, w. IDC cable assemblies |
| SU3-ENSEMBLE | 8/16 x configurable isolated RS-232 RS-485 ports, carrier card for up to 8 modules, connector styles RJ45/Micro-D/D-Sub, rear I/O capable 4+4, to be combined with single port modules SUE - SUJ | 4HP/8HP/12HP F/P, for rear I/O to be combined with SUC-RIO as rear I/O carrier card for single port modules SUE - SUJ, 16 ports as dual SU3-ENSEMBLE with a common front panel 12HP |
| SU4-SOPRANO | 8 x RS-232/485 selectable, non isolated, Micro-D | 4HP F/P, each port user configurable, rear I/O capable |
| SU5-ENSEMBLE | same as SU3 but 58.9824MHz UART clock option for highest RS-485 data rates available | same as SU3, except baud rates (refer to table on previous page) |
| SUA-RIO | 4 x isolated RS-232, Micro-D | 4HP R/P rear I/O card for SU1/SU2 8HP F/P when used as SU1/SU2 mezzanine |
| SUB-RIO | 4 x isolated RS-485, Micro-D | 4HP R/P rear I/O card for SU1/SU2 8HP F/P when used as SU1/SU2 mezzanine |
| SUC-RIO | 4 x configurable isolated RS-232 RS-485 ports, carrier for up to 4 transceiver modules SUE - SUJ, connector styles RJ45/Micro-D/D-Sub | 4HP R/P rear I/O card for SU3 8HP F/P when used as SU3 mezzanine to be combined with single port modules SUE - SUJ |
| SUE-RS232 | 1 x RS-232 isolated transceiver module Micro-D | for SU3, SU5, SUC |
| SUF-RS485 | 1 x RS-485 isolated transceiver module Micro-D | for SU3, SU5, SUC |
| SUG-RS232 | 1 x RS-232 isolated transceiver module RJ45 | for SU3, SU5, SUC |
| SUH-RS485 | 1 x RS-485 isolated transceiver module RJ45 | for SU3, SU5, SUC |
| SUI-RS232 | 1 x RS-232 isolated transceiver module D-Sub | for SU3, SU5, SUC |
| SUJ-RS485 | 1 x RS-485 isolated transceiver module D-Sub | for SU3, SU5, SUC |

Ordering Information

Ordering Information

For popular SU1-TWIST SKUs please refer to www.ekf.com/liste/liste_21.html#SU1

| Ordering Number Key | | |
|--|---------|--|
| SU1-abcd-TWIST (Availability on Request) | | |
| a | 0 | EKF standard product |
| | 1- | tbd, suitable for mezzanine and custom applications |
| b | | number of physical UART (COM) ports (maximum 8 w. SUA/SUB-RIO) |
| | 1 | basic product (4 Micro-D connector front ports) |
| | 2, 3, 4 | number of D-Sub connector front ports |
| | 8 | 4 front ports, board suitable for assembly with SUA/SUB-RIO for a total of 8 ports |
| c | | SU1 connector type and pin assignment |
| | 0 | basic product Micro-D (???) pinout) |
| | 1 | Micro-D (SU4 pinout) |
| | 2 | D-Sub 9-pin (DU1 pinout) |
| | 3 | D-Sub 9-pin (CU4 pinout) |
| | 4 | D-Sub 9-pin (WL custom pinout) |
| | 5 | RJ45 jack (CU4 pinout) |
| | 6 | D-Sub 9-pin (2 wire connection customizable pinout) |
| | 7 | RJ45 jack (CUD 2 wire connection pinout) |
| | 8 | RJ45 jack (CUD 4 wire connection pinout) |
| | 9 | reserved |
| d | 0 | feature set 00000 = basic product |
| | 1-Y | tbd special feature sets 00001-11110 |
| | Z | feature set 11111 = EKF design verification product |

Beyond All Limits: EKF High Performance Embedded



Industrial Computers Made in Germany
boards. systems. solutions.

Document No. 8446 • 16 March 2023

EKF Elektronik GmbH
Philipp-Reis-Str. 4 (Haus 1)
Lilienthalstr. 2 (Haus 2)
59065 HAMM
Germany



Phone +49 (0)2381/6890-0
Fax +49 (0)2381/6890-90
Internet www.ekf.com
E-Mail sales@ekf.com